



INDUSTRIAL GROUP

www.aqua.it

INSTALLATION AND INSTRUCTION MANUAL



DH series MOBILE DEHUMIDIFIER

- ▶ *Air dehumidifiers*
- ▶ *Operation*
- ▶ *Technology*
- ▶ *Replacement parts*



DH-2
DH-4
DH-6
DH-15



*Read these operating instructions carefully
before commissioning / using this device!*

AQUA

Contents

<i>Air dehumidification</i>	4
<i>Safety notes</i>	6
<i>Intended use</i>	7
<i>Customer service and warranty</i>	7
<i>Environmental protection and recycling</i>	7
<i>Unit description</i>	8
<i>Set-up</i>	9
<i>Commissioning</i>	10
<i>Decommissioning</i>	12
<i>Transportation</i>	12
<i>Care and maintenance</i>	13
<i>Troubleshooting</i>	14
<i>Electrical connection diagram</i>	15
<i>Maintenance protocol</i>	16
<i>Technical data</i>	17



These instructions are an integral part of the unit and must always be kept in the vicinity of the installation location or on the unit itself.

Subject to modifications; no liability accepted for errors or misprints!

Air dehumidification

The correlations occurring when air is dehumidified are based on physical laws.

These are depicted here in graphical form in order to provide you with a brief overview of the principles of air dehumidification.

The use of AQUA air dehumidifiers

- Even if Windows and doors are well insulated, water and moisture are capable of penetrating even thick concrete walls.
- The water required for setting in the production of concrete, mortar and plaster etc. may only be diffused after 1-2 months.
- Even moisture trapped in the masonry after high-water or a food is released very slowly.
- The same is also true of moisture contained in for example stored materials.

The moisture (water vapour) released from parts of a building or materials is absorbed by the surrounding air. As a result, the moisture content increases, which ultimately gives rise to corrosion, mould, rot, peeling of paint and other unwanted damage.

By way of example, the diagram shows the corrosion rate of metal in different levels of humidity.

It is evident that the corrosion rate below 50% relative humidity (RH) is low, and below 40% is negligible.

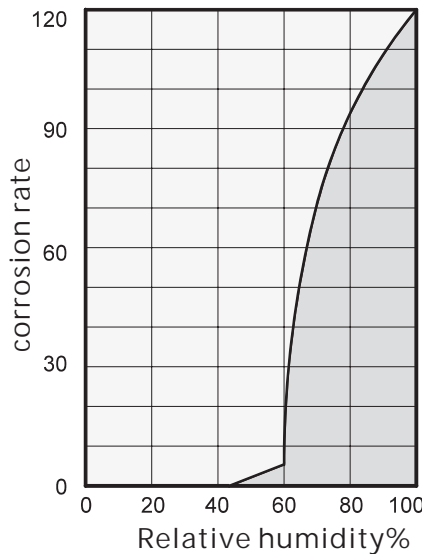

The corrosion rate increases significantly above 60% RH. This threshold for damage as the result of humidity also applies to other materials, such as powdery substances, packaging, wood and electronic units.

Buildings may be dried in a variety of

1. By heating and air exchange:

The air in the room is heated in order for moisture to be removed and drained outside. All of the energy that is involved is lost together with the moist air that is released.

2. By air dehumidification:

The moist air that is present within an enclosed space is continuously dehumidified according to the condensation principle.

With regard to energy consumption, air dehumidification has one distinct advantage:

Energy expenditure is limited exclusively to the air volumes present., The mechanical heat that is released by the dehumidification process is fed back into the room.

Under normal use, the air dehumidifier uses approximately 25% of the energy that is required for the "heating and ventilating" principle.

Relative humidity

Our ambient air is a gaseous mixture which always contains a certain volume of water in the form of water vapour. This volume of water is specified in g per kg of dry air (absolute moisture content).

1m³ of air weighs approx. 1.2 kg at 20° C

Depending on the temperature, each kg of air is only capable of absorbing a certain volume of water vapour. Once this capacity has been reached, the air is referred to as "saturated" and has a relative humidity (RH) of 100%.

Relative humidity is understood to mean the ratio between the current volume of water vapour in the air and the maximum possible volume of water vapour at the same temperature.

The ability of the air to absorb water vapour increases as the temperature rises. I.e. the maximum possible (absolute) water content becomes greater as the temperature rises.

Air dehumidifiers

Temp. °C	Water vapour content in g/m ³ at humidity of			
	40%	60%	80%	100%
-5	1,3	1,9	2,6	3,3
+10	3,8	5,6	7,5	9,4
+15	5,1	7,7	10,2	12,8
+20	6,9	10,4	13,8	17,3
+25	9,2	13,8	18,4	23,0
+30	12,9	18,2	24,3	30,3

 The condensation of water vapour

Because the capacity for the maximum possible volume of water vapour increases as the air is heated, the volume of water vapour contained remains constant and so relative humidity falls.

In contrast, because the capacity for the maximum possible volume of water vapour decreases as the air is cooled, the volume of water vapour contained remains constant and so relative humidity increases.

If the temperature continues to fall, the capacity for the maximum possible volume of water vapour is reduced so much so that it is ultimately equal to the volume of water vapour contained in the air.

This temperature is referred to as "dew point". If the air is cooled to below dew point, the volume of water vapour in the air will become greater than the maximum possible volume of water vapour.

At this point, the water vapour begins to precipitate. It then condenses to water. The air is then deprived of humidity.

Examples of condensation include steamed-up window panes in winter, or the moisture on the outside of a cold drinks bottle.



As the relative humidity of the air increases, so too does dew point, making it easier for the temperature to fall below it.

Drying materials

Building materials and structures are capable of absorbing considerable volumes of water, such as brick 90-190 l/m³, heavy concrete 140-190 l/m³ and limestone 180-270 l/m³.

The drying of moist materials such as masonry is effected as follows:

- The moisture moves from the inside of the material to its surface

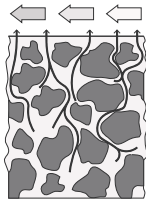

- Evaporation occurs on the surface = Transfer of water vapour to the ambient air

- The air containing water vapour is constantly circulated through the AQUA air dehumidifier. The air is dehumidified and, slightly heated, leaves the unit in order to re-absorb water vapour.

- In this way, the moisture contained in the material is reduced gradually. The material is dried!

The accumulated condensate is collected in the unit from where it is drained off.

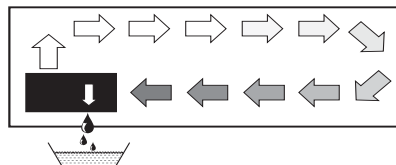

As it flows through or over the evaporator, the air stream is cooled to dew point. The water vapour condenses, and is collected in a condensate trap from where it is drained off.

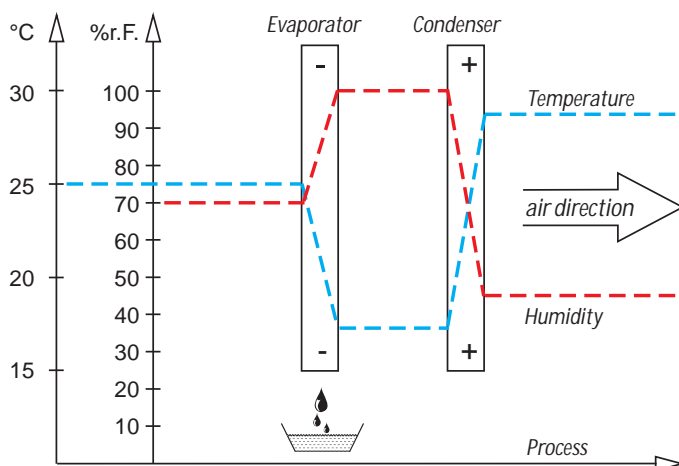

Air dehumidifiers

Condensation heat

The Energy transferred to the air from the condenser consists of:

1. the amount of heat derived beforehand in the evaporator.
2. the electrical drive energy.
3. the condensation heat released by the liquefying of the water vapour.

Energy must be supplied when liquid is converted into a gas. This energy is designated as evaporation heat. It does not cause any increase in temperature, but is required to convert a liquid into a gas. Conversely, energy

is released when gas is liquefied, this is designated as condensation heat.

The amount of energy from evaporation heat and condensation heat is the same.

For water, this is:
2250 kJ/kg (4.18 kJ = 1kcal)

From this it is evident that the condensation of water vapour causes a large quantity of energy to be released.

If the moisture that it is to be condensed is not introduced by evaporation in the room itself, but from outside, e.g. through ventilation, the condensation

heat released contributes to the heating of the room. With drying operations, a heat cycle is created, whereby heat is consumed for evaporation and released for condensation. When dehumidifying fed air, a larger contribution of heat is created, which manifests itself as a temperature increase.

Generally speaking, the time required for the drying process is not only dependent on the output of the unit, but is determined to a greater extent by the speed at which the material or building section loses its moisture.

Safety notes

The units were subjected to extensive material, functional and quality inspections prior to delivery. However, dangers can emanate from the units if they are used improperly or not as intended by untrained personnel!

The following notes must be observed in full:

- The units may not be installed or operated in explosive environments
- The units must not be installed or operated in atmospheres containing oil, sulphur, chlorine or salt
- The units must be installed upright and in a stable position
- The units must not be exposed to direct jets of water

- An unobstructed air inlet and air outlet must be guaranteed at all times
- The air-inlet grille must always be kept free of dirt and loose objects
- The units must not be covered during operation
- Never stick foreign objects into the units
- The units must not be transported during operation
- The units must only be transported when the condensate container is empty and the evaporator is dry
- All electrical cables on the outside of the units must be protected against damage (e.g. by animals etc.)

- Before each change of location, the condensate container must be emptied

ATTENTION

Extensions to the connection cable must only be conducted by authorised specialist electricians, taking into consideration the unit power consumption, cable length and local use.

ATTENTION

Work on the refrigerant system and on the electrical equipment must only be conducted by a specially-authorized specialist.

Intended use

The units are designed exclusively for drying and dehumidification purposes in industrial or commercial situations on the basis of their structural design and equipment.

The units must only be operated by appropriately instructed personnel.

With non-observance of the manufacturer's specifications, the respective local legal requirements or after arbitrary alterations to the units, the manufacturer shall not be liable for resulting damages.

NOTE

*Operation other than the types listed in this operating manual is prohibited.
With non-observance, any liability and claim to warranty expire.*

ATTENTION

*Copyright
The redistribution, even in part, or the use of this documentation for purposes other than intended is strictly prohibited without the written authorisation of AQUA*

Customer service and warranty

In order to make warranty claims, it is essential that the ordering party or their representative complete and return the "certificate of warranty" to AQUA at the time when the equipment is purchased and commissioned.

The units were inspected multiple times to verify their correct function. However, if malfunctions should arise that cannot be remedied by the operator with the assistance of the troubleshooting section, please contact your specialist dealer or contractual partner.

NOTE

*Installation work may only be carried out by authorised qualified technicians.
by authorised specialists.*



Important information concerning recycling

The units are operated with environmentally-friendly and ozone-neutral R22 refrigerant.

The mixture of refrigerant and oil within the unit must be disposed of properly in accordance with the statutory or locally-applicable regulations.



Environmental protection and recycling

Disposing of packaging

When disposing of packaging material, please consider our environment.

Our units are carefully packed and delivered in stable cartons for transportation and, if applicable, on a wooden pallet.

The packaging materials are environmentally-friendly and can be recycled.

By recycling packaging materials, you make a valuable contribution to the reduction of waste and conservation of raw materials.

Therefore, only dispose of packaging material at appropriate collection points.

Disposal of the old unit

The manufacturing process for the units is subject to continuous quality control.

Only high-grade materials are processed, the majority of which are recyclable.

You also contribute to environmental protection by ensuring that your old equipment is only disposed of in an environmentally-friendly manner.

Therefore, only bring the old unit to an authorised recycling business or to an appropriate collection point.



Air dehumidifiers

Unit description

The units have been designed for universal and straightforward air dehumidification.

Their compact dimensions allow the unit to be transported and set up with ease.

The units operate in accordance with the condensation principle and are equipped with a hermetically sealed refrigerant system, low-noise and low-maintenance fan, the fully automatic electronic control, built-in humidistat and connection cable with plug and hydrants for the on-site Condensate ensure trouble-free use.

The units conform to the fundamental health and safety requirements of the appropriate EU stipulations. The units are dependable and offer ease of operation.

Locations at which units are used

The units are used in all locations, where dry air is a must and where economic consequential damage (such as that caused by mould) must be prevented.

The units may be used for the drying and dehumidification of areas such as :

- New buildings, industrial buildings
- Basements, storage rooms
- Archives laboratories
- Weekend homes, caravans
- Bathrooms, wash rooms and changing rooms etc.

Operating sequence

The unit is switched on by pressing the operating switch. It then operates in continuous fully-automatic operation.

The fan extracts the moist room air through the dust filter, evaporator and the condenser behind.

Heat is removed from the room air on the cold evaporator. The air is then cooled to below dew point. The water vapour contained in the room air is then deposited as condensate or rime on the evaporator fins.

If the temperature sensor here measures a pre-set minimum, it activates a time relay. If the evaporator temperature stops increasing during this period, the cooling cycle switches to hot gas defrosting after the timer cycle.

The fan remains out of operation during the defrosting phase. As soon as the rime (ice) has been defrosted and the temperature at the sensor has increased above a pre-set level, the unit switches

back to normal dehumidification mode.

If the room temperature is sufficiently high, the surface of the fins will not be cold enough for rime formation to occur, rendering defrosting unnecessary. Therefore, the air dehumidifiers work economically.

The cooled and dehumidified air is re-heated by the condenser (heat exchanger), and blown back into the room through the outlet grille. The processed, dry, heated air then re-mixes with the room air.

Continuous circulation of the room air through the unit gradually reduces the relative humidity (% RH) in the room to the desired humidity level

Depending on the room temperature and the humidity, only 30- 40% electrical energy is required, in accordance with the output of the unit.

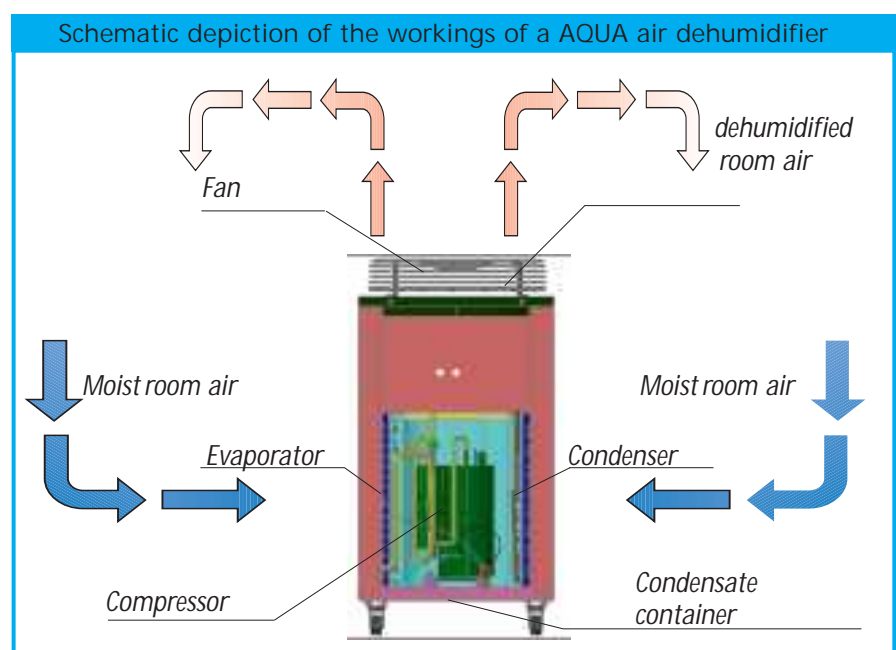

Set-up

For the best economic and safe use of the units, the following notes must be followed in full:

- The units must be set up in an upright and level position, so as to ensure unobstructed flow of the condensate
- To ensure optimum air circulation, the units should be set up in the centre of the room, where possible
- It must be ensured that the air can be sucked in on the front of the unit and blown out of the rear of the unit without obstruction
- Observe a minimum clearance of 50cm from walls at all times
- Units must never be set up in the immediate vicinity of heaters or other sources of heat
- Air circulation is improved if the unit is set up approx. 1 m above the ground
- The room being dried or dehumidified must be closed to the neighbouring atmosphere
- Avoid having opened windows and doors etc., and avoid frequent entry to or exit from the room as much as possible
- If the units are to be used in dusty environments or stables, appropriate care and maintenance measures should be taken according to the relevant conditions
- The output of the unit is entirely dependent on the conditions inside the room, room temperature, relative humidity and observance of the set-up instructions

Electrical connection

- The units are operated with 220 V/ 50 Hz alternating current.
- The electrical connection is made using a built-in mains cable with earthed safety plug

NOTE

The electrical connection to the units must be made at feed points with residual current devices in accordance with VDE 0100, Section 704. When installing the units in extremely damp environments such as laundry rooms, showers etc., the customer must ensure that the unit is secured with a residual current device in accordance with the regulations.

- Extensions to the connection cable may only be carried out by authorised electricians, subject to the length of the cable, connected load of the unit and taking into consideration how the unit is used at its location

ATTENTION

All cable extensions must only be used in a rolled out or unrolled state.

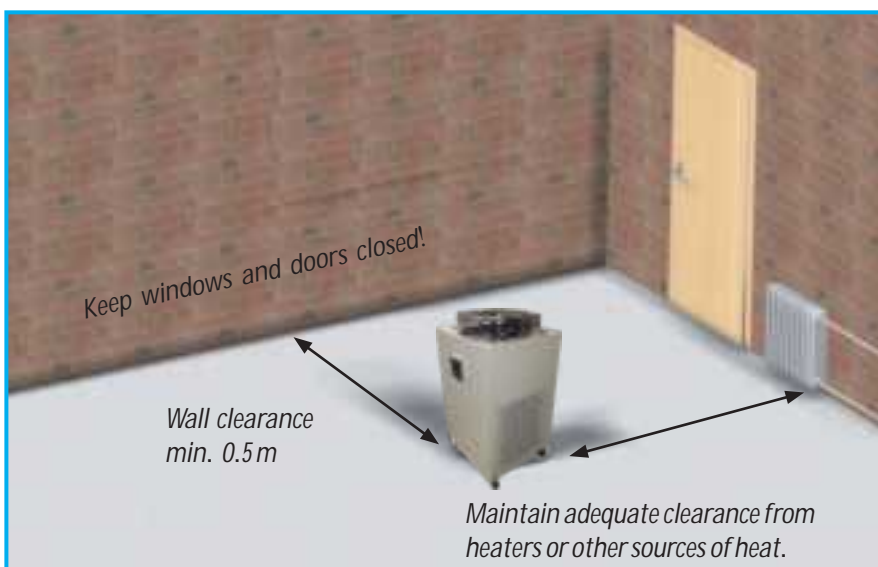

Commissioning

Before commissioning the unit or if local requirements dictate, the air-inlet grille and air-outlet grille must be checked for contamination.

NOTE

A contaminated grille or filter must be cleaned or replaced immediately.

Important points prior to installation

- All extensions to the electrical connection must be of a sufficient cable size and must only be used fully rolled out or unrolled
- Never use the mains cable as a pull cord
- After being switched on, the units operate fully-automatically until switched off by the float when the condensate container is full
- The condensate container must be inserted properly and the sealing flap must be locked

NOTE

The units are only functional when operated with a correctly inserted condensate container.

NOTE

In room temperatures below 10°C and relative humidity below 40%, economical use of the unit can no longer be guaranteed.

Operation and gauge



- [Power] = Turn ON or OFF
- [M] = Enter parameter setting status
- [Up] [Down] = Check or set the parameter
- [Left] = Invalid
- [Timer] = Set timer

Before connect the dehumidifier to power supply, it must be checked all the connections of dehumidifier are well connected. After connect to power, LCD initialization (shown as above figure), and then enter standby status, shown as below figure:



Target humidity value
Measured value (can not be changed)

Starting the unit

- Move the operating switch [2] to the "0" (off) position.
- Connect unit mains plug to a properly installed and protected mains socket 220V/ 50 Hz



- Move the operating switch [2] to the "0" (off) position.



- The green control lamp "in operation" will illuminate and the unit will operate in fully-automatic dehumidification mode.

- Press [M] start the dehumidifier, LCD displayed as below figure:



The unit has two modes Press "M" key to select fan mode or dehumidification mode

- Select dehumidification mode and set the desired air humidity. Press [Up] to [Down] adjust the target humidity value (Range: 1%-99%). Set the value, and wait for 10 seconds, system save the setting automatically. (The value stops flashing, setting is saved.)

Timer setting:

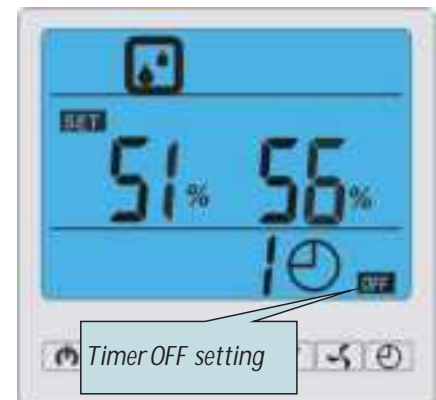

- Timer OFF must be set under running status. Press [Timer] to enter timer setting status, LCD shows as below:

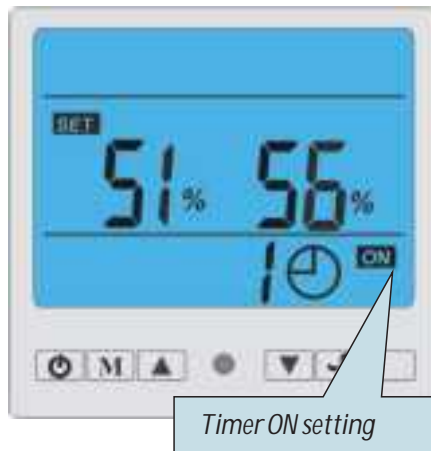

Air dehumidifiers

b. Timer ON must be set under standby status. Press  to enter timer ON setting status, LCD shows as below:



After enter the timer setting status, the value is flashing, press  and  to set timer ON/OFF, value range 1-24.

Set the value, and wait for 15 seconds, setting is saved.



The timer setting will be eliminated after disconnected from electricity or power failure, in this case, timer should be reset after the recovery of electricity.

Turn off the dehumidifier

Press  turn off the dehumidifier, LCD displayed as below figure:



Key composite function

Press the "" key and "" key for 3 seconds to turn on/off keyboard lock.

Fan speed settings





Starting the unit, press  to change the fan speed.

Parameter query and set

Press the  seconds to enter the parameter query set menu parameters as follows:

No.	Parameter	Code Meaning	Parameter Description	Default values
1	C1	Heating function	0-1	1
2	C2	Condensation (coil) temperature	-20-99°C	
3	C3	Humidity sensor detects deviation	-5% ~ 5%	0%
4	C4	Press after opening delay detection time	20 ~ 90min	40
5	C5	Enter the defrost point temperature	-10 ~ 10°C	-1
6	C6	Exit defrost point temperature	0°C ~ 15°C	8
7	C7	Maximum defrost time	2 ~ 12min	8

NOTE

Press the  seconds parameter values in to display C1 and C3 when flashing  and  keys to set parameter values. Press  key to exit the settings.

Fault protection code

Press the  seconds to enter the parameter query set menu parameters as follows:

No.	Protection / failure	Screen display
1	Room temperature sensor failure	E1
2	Coil temperature sensor failure	E2
3	Humidity sensor failure	E3
4	High-pressure protection	E4
5	Low-pressure protection	E5
6	Flow switch failure	E6
7	Phase sequence failure	E8
8	Communication failure	EE

Air dehumidifiers

Condensate

Depending on the air temperature and the relative humidity, condensed water will drip into the condensate trap and into the condensate container below either continuously or only during the defrosting phases.

Unit rear side of the least significant bit, a condensate drain interface, you need to be connected to the drains timely condensate discharge.

The drains recommend rubber hose, drainage to drain



NOTE

Beware of dripping condensate. After switching off the units, the evaporator may continue to defrost under the influence of the ambient temperature.

Unit operation with hose connection

The condensate container has been provided with a connection port ($\varnothing 20\text{mm}$). After removing the condensate container, a water hose (not provided) may be connected to this connection port.



The following procedure must be followed when connecting a water hose:

1. Open the front sealing flap and remove the sealing plug.
2. Insert the customer provided drainage hose into the connection port (secure and seal with a clamp if necessary).
3. Insert the condensate container back and route the drainage hose through the slot on the right next to the condensate container through the base of the unit.



4. Lock the front sealing flap in place.



5. Drain the condensate into a lower-lying drain.

To operate the units, the condensate container must always be inserted correctly and the sealing flap must always be locked.

NOTE

Ensure that the drainage hose is placed at an angle to the drain to allow the condensate to drain from the condensate container without hindrance.

Decommissioning

Move the operating switch to the "0" (off) position.



ATTENTION

In order to prevent damage to the compressor, wait for approx. 2 to 3 minutes before switching the unit back on again.

If the units are to be left unused for extended periods, disconnect from the mains.

Empty drain the water inside, and maintain a mains unimpeded.

NOTE

Beware of dripping condensate. After switching off the units, the evaporator may continue to defrost under the influence of the ambient temperature.

When storing the unit, cover with a plastic sheet/foil if necessary and store in an upright position in a sheltered and dry location.

Transportation

For easy transportation, the units are equipped with 4 large wheels and an easy-to-dismantle transportation handle.

When transporting the units, observe the following:

1. Before each change of location, switch off the unit and remove the mains plug from the mains socket.

NOTE

Beware of dripping condensate. After switching off the units, the evaporator may continue to defrost under the influence of the ambient temperature.

2. Empty the condensate drain.

3. If moisture remains on the evaporator or water remains in the condensate container, the units must only be transported in an upright position.

ATTENTION

The mains cable must never be used as a pull cord or fixing device.

Care and maintenance

NOTE

Regular care and maintenance is fundamental to a long service life and fault-free operation of the unit.

All moving parts have a low-maintenance permanent coat of lubricant. The refrigerant system is designed as a hermetically sealed system and may only be repaired by a specialist.

ATTENTION

Before undertaking any work on the units, the mains plug must be removed from the mains socket.

- Observe the regular care and maintenance intervals
- In accordance with the operating conditions, the units must, if necessary, be checked at least yearly by a specialist to ensure that they are in a condition that is safe to use
- Keep the units free of dust and other debris
- Only clean the units with a dry or moistened cloth

- Never subject to direct jets of water such as a high-pressure cleaner etc.
- Never use abrasive or solvent-based cleaners
- Use only suitable cleaners for heavy contamination

Cleaning the dust filter

ATTENTION

Check the inlet and outlet grille and the dust filter for contamination on a regular basis.

Slide the protective grille upwards slightly, then pull forwards and remove downwards.

Then remove the dust filter which has now been released.

Light contamination of the dust filter may be remedied with careful blowing or suction.

Heavier contamination may be remedied by rinsing the filter in a lukewarm (max 40°C) soap solution.

Finally, always ensure to rinse the filter carefully with clear water and allow to dry.

Before refitting the dust filter, ensure that its fully dry and that no damage has been sustained.

NOTE

Heavily contaminated dust filters must be replaced with new parts. Only original replacement parts may be used

The units may only be operated with the dust filter in place.

Cleaning the units

The unit housing must be opened to allow the inside of the unit to be cleaned and to provide access to electrical components.

NOTE

Installation work may only be carried out by authorised qualified technicians. by authorised specialists.

1. Remove the mains plug from the mains socket.
2. Clean the condenser fins by blowing, with suction or using a smooth brush.
3. Exercise extreme caution when cleaning the condenser. The fine aluminium fins bend very easily.
4. Never subject to sharp jets of water (high-pressure cleaners).
5. Clean the evaporator fins, for example with a lukewarm soap solution (or similar).
6. Rinse with clean water to remove any remaining soap.
7. Clean the internal surfaces of the entire unit as well as the fan blade.
8. Once cleaning has been completed, the unit should be dried with care. Take particular care with electrical components!
9. Re-install all dismantled components in reverse order.
10. Carry out a unit function check and electrical safety check.

ATTENTION

An electrical safety check must be carried out in accordance with VDE 0701 after any work on the units.

Troubleshooting

The units are manufactured using state-of-the-art production methods and tested several times to verify their correct function. However, if a functional fault should occur, the unit should first be checked in accordance with the following list:

ATTENTION

Work on the refrigerant system and on the electrical equipment must only be conducted by a specially-authorised specialist.

The unit does not start

- Check the setting of the operating switch. The green control lamp should illuminate
- Check mains connection 220V/1~/50 Hz
- Check mains plug and cable for damage
- Check the customer-provided mains protection. Minimum protection 10A
- Check the level and correct positioning of the condensate container. The front sealing flap must be fully closed and locked
- Check the function of the micro switch
- Check the setting of the humidity switch (accessories). The pre-set value must be lower than the relative humidity in the room.
- Check the humidity switch adapter for damage and correct positioning

The unit runs but does not form any condensate

- Check the room temperature. The operating range of the unit is between 3° C and 32° C
- Check the humidity of the air, min. 40% RH required
- Check the setting of the humidity switch, set a lower humidity value if necessary
- Check the dust filter for contamination and clean or replace if necessary
- Check the evaporator and condenser fins for contamination and clean if necessary
- Check the evaporator for ice or rime formation. If ice has formed, check the functionality of the automatic defrost and the temperature sensor
- Check whether or not the evaporator temperature is below room temperature. If this is not the case, check the automatic defrost or room temperature

The unit does not start

- Check whether or not the condensate container is inserted correctly and that the front sealing flap is locked
- Check whether or not mains power is available

NOTE

If the unit fails to function correctly after the checks have been carried out, an authorised specialist must be informed.

Air dehumidifiers

Electrical connection diagram

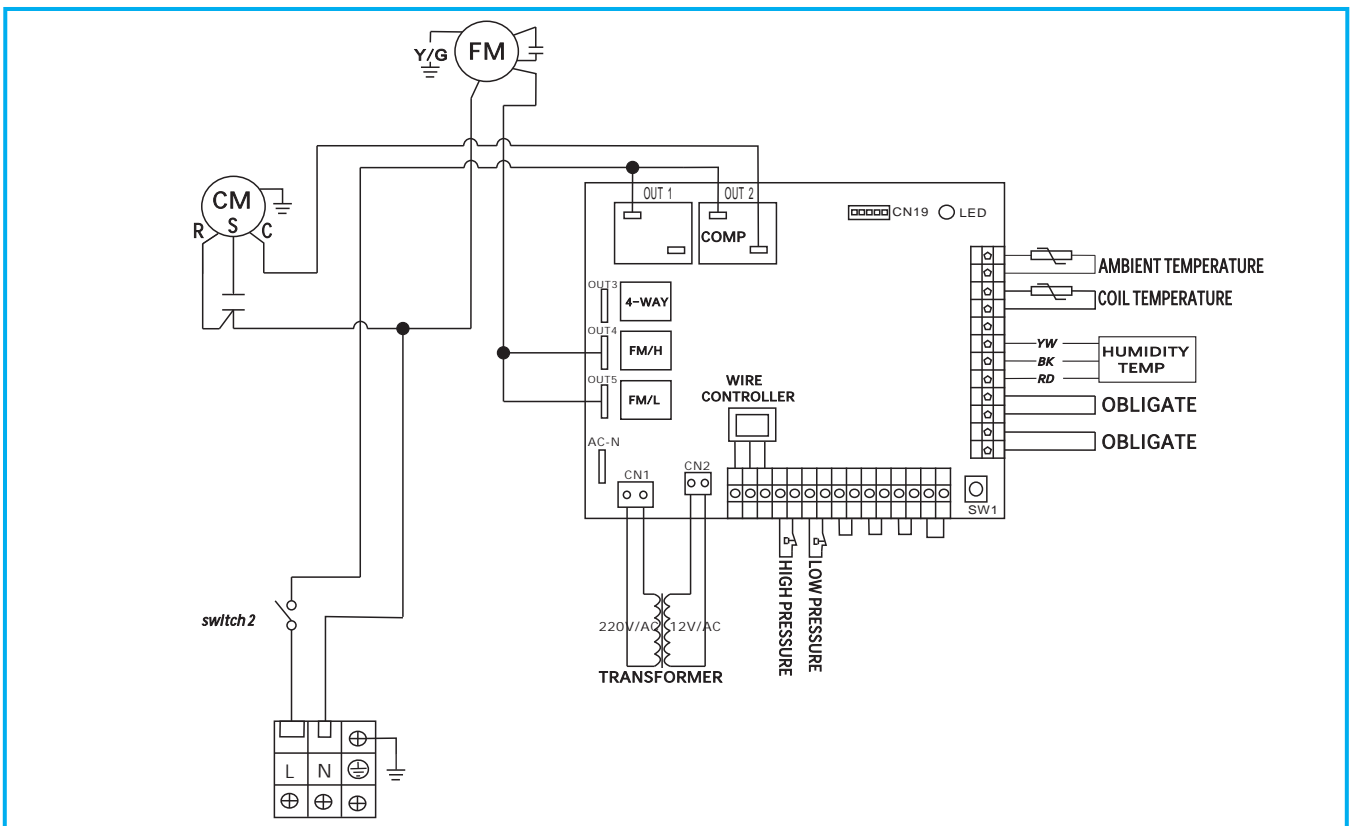
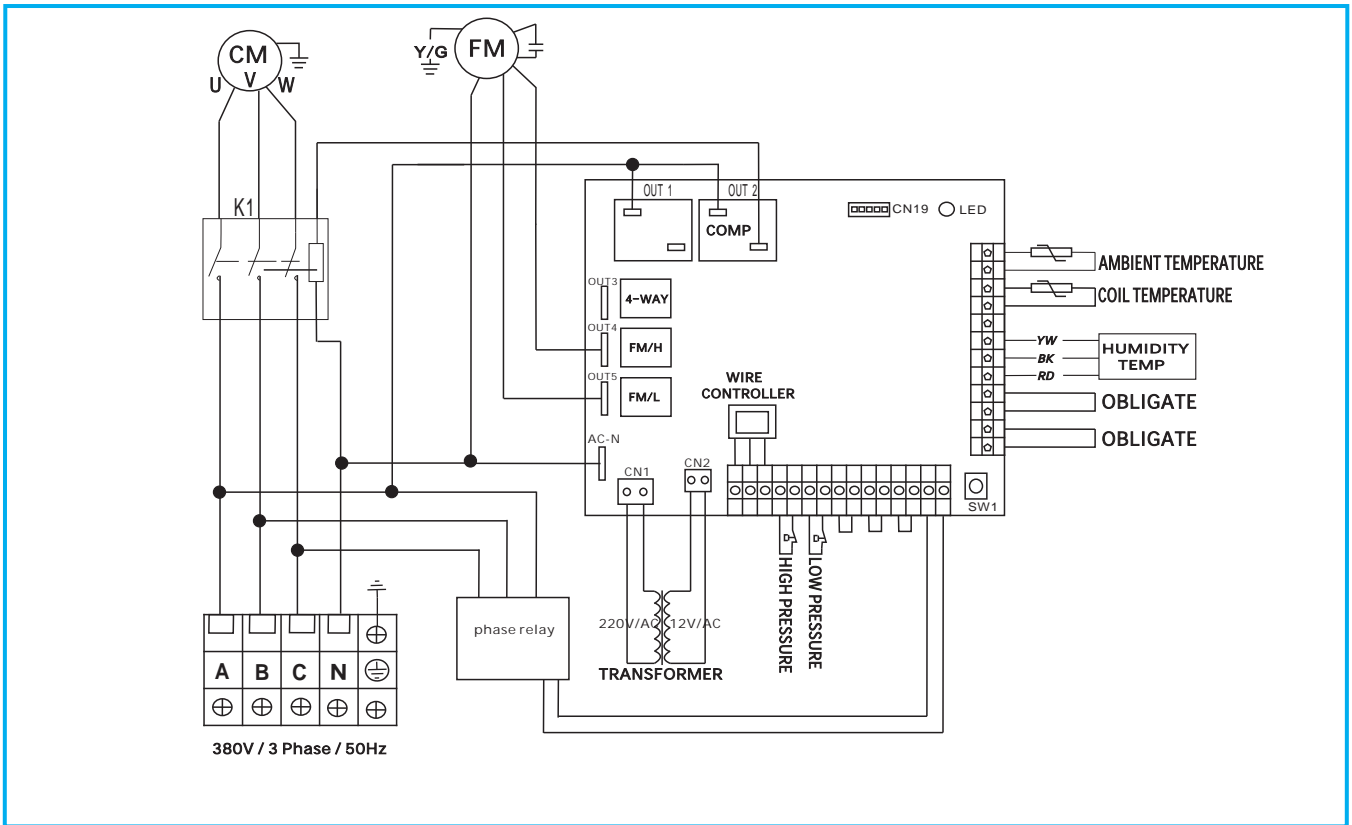

We reserve the right to modify the dimensions and constructional design as part of the ongoing technical development process.



Maintenance protocol

Unit type: Unit number:

	1	2	3	4	5	6	7	8	9	10	11	12	13	14	15	16	17	18	19	20
Unit cleaned - outside -																				
Unit cleaned - inside -																				
Fan blade cleaned																				
Fan housing cleaned																				
Condenser cleaned																				
Vaporiser cleaned																				
Fan function checked																				
Air-inlet grid with filter cleaned																				
Unit checked for damage																				
Safety devices checked																				
All fastening screws checked																				
Electrical safety check																				
Test run																				

Comments:

1. Date: Signature:	2. Date: Signature:	3. Date: Signature:	4. Date: Signature:	5. Date: Signature:
6. Date: Signature:	7. Date: Signature:	8. Date: Signature:	9. Date: Signature:	10. Date: Signature:
11. Date: Signature:	12. Date: Signature:	13. Date: Signature:	14. Date: Signature:	15. Date: Signature:
16. Date: Signature:	17. Date: Signature:	18. Date: Signature:	19. Date: Signature:	20. Date: Signature:

Unit to be maintained only by authorised specialists in accordance with the statutory regulations.

Air dehumidifiers

Technical data

Series		DH-2	DH-4	DH-6	DH-15
Operating range, temperature	°C	3-32	3-32	3-32	3-32
Operating range, humidity	% RH	40-100	40-100	40-100	40-100
Dehumidification capacity max.	l/h	2.2	4.1	6.2	15.2
at 30° C/80% RH	l/h	2.0	3.9	6.0	15.0
Ventilation capacity max.	m ³ /h	400	1000	2800	4500
Condensate drain Size	mm	Φ20	Φ20	Φ20	Φ20
Compressor/condenser	Configuration	Rotary	Rotary	Rotary	Scroll
Refrigerant	Freon	R22	R22	R22	R22
Refrigerant quantity	g	450	900	1400	2400
Power supply	V/Hz	220-240/1~150	220-240/1~150	220-240/1~150	380V/3~150
Max. rated power consumption	A	3,4	6.9	10.5	8.1
Max. power consumption	kW	0,76	1.53	2.3	2.3
at 20° C/70% RH	kW	0,53	1.1	1.7	6.2
Customer-provided electrical protection	A	16	16	16	40
Defrosting	Automatic	Hot gas	Hot gas	Hot gas	Hot gas
Sound pressure level L _{pA 1m} ¹⁾	dB(A)	45	49	49	53
Depth	mm	280	490	490	770
Width	mm	960	490	490	770
Height	mm	520	950	950	995
Height incl. Transportation bracket	mm	600	1040	1040	1090
Weight	kg	46	50	55	165

1) Noise level measurement DIN 45635 - 13 - KL 3

2) Dimensions in () = without transportation bracket

We reserve the right to modify the dimensions and constructional design as part of the ongoing technical development process.



AQUA S.p.A.: 42018 San Martino in Rio, (RE) / Phone:+39 0522 695805/85 - Fax:+39 0522 646160
e-mail:aqua@aqua.it - Web:www.aqua.it